

OPTION #1

Second Weld Robot - Agen Trio Preparation:

With this optional second welding tower gantry comes. In this way, welding times are reduced and productivity increases. Agen Duo becomes, Agen Trio.

AGEN
— D U O —



AGEN
— T R I O —

Second Weld Tower

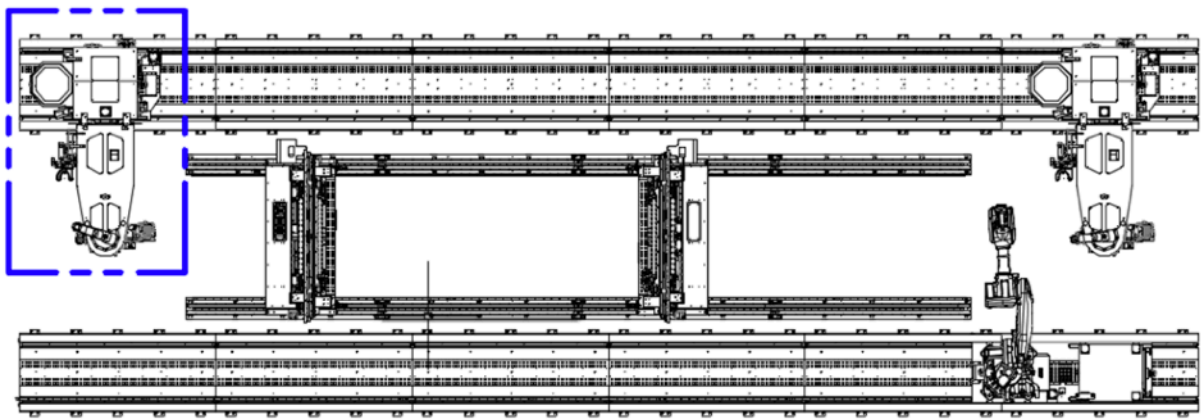

FUTURE OPTION #2

Profile Width - 1500mm:

With this optional profile width increases from 1.100mm (43") to 1.500mm (59") . Positioners and weld tower gantry are upgraded in this option.

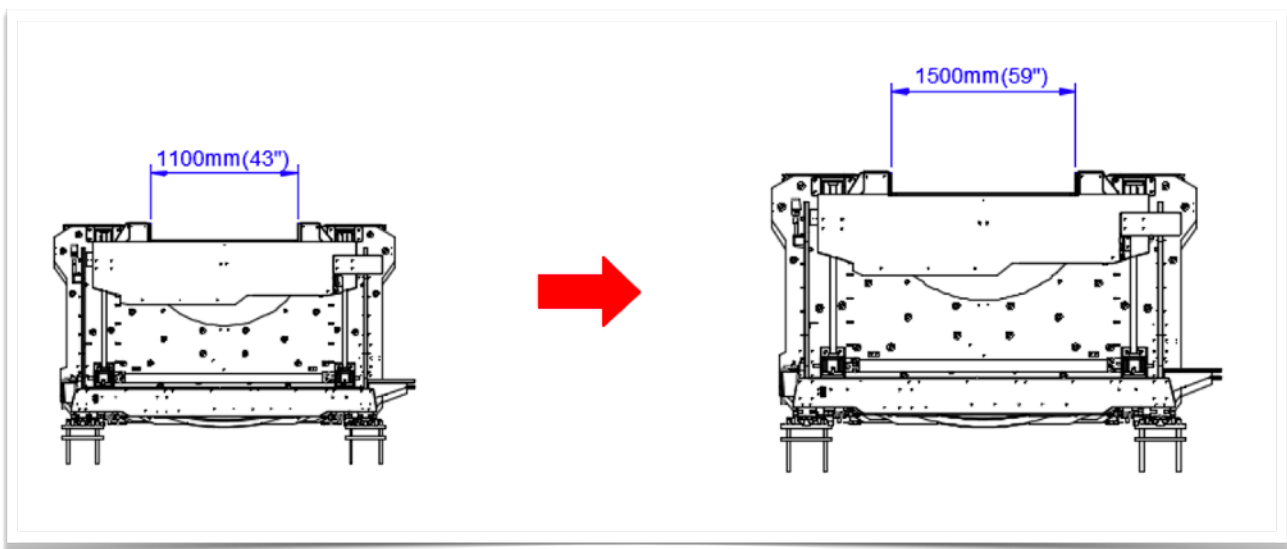

OPTION #3

Product length up to 15m:

Main part length can be up to 15m (49'3") . In base configuration default length is 12m (39'4") .

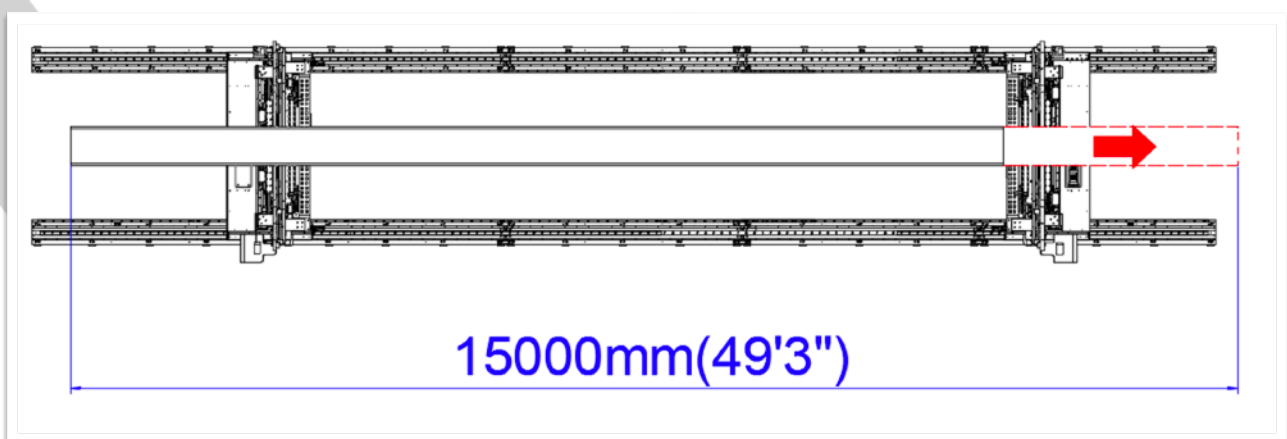

OPTION #4

Product length up to 18m:

Main part length can be up to 18m (59') . In base configuration default length is 12m (39'4") . Positioners are upgraded.

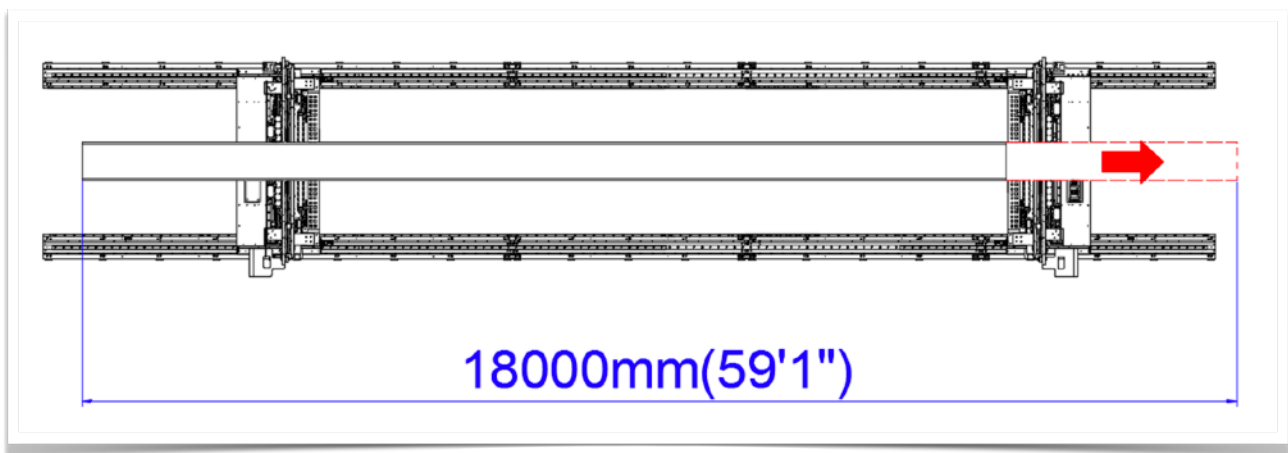

OPTION #5

Magnet gripper -Mag0:

Mag0 is for picking small parts with widths from 3" to 5". It has 2 poles.

OPTION #6

Corner frame application:

With this option system is capable of doing haunched connections.



OPTION #7

Angle profiles as ADD part:

With this option system is capable of assembling L shaped profiles as ADD part.



OPTION #8

Additional Abka01 workplace license or additional CAD program support:

In order to get additional workplace license to work simultaneously in more than one computer to create work orders for Agen System. Also need to get this option, in order to get Agen Export Tool which is compatible with CAD programs except Tekla Structures.



OPTION #9

Lights out manufacturing - Full Remote Control:

With this option full remote control support is added to the system. Operator can connect and run the machine remotely. Also it comes with an industrial tablet PC.



OPTION #10

Pre-heating system:

For thick base plates, with this option, in order to prevent heat deformations, pre-heating is done prior to welding. Only valid for base plates and from one side. (Close to system zero point)



OPTION #11

In-feed conveyor system:

In order to mechanize the in feed for Agen System. It comes with one cross- conveyor and one feed conveyor. Positioners can pick the profile automatically without the need for operator.

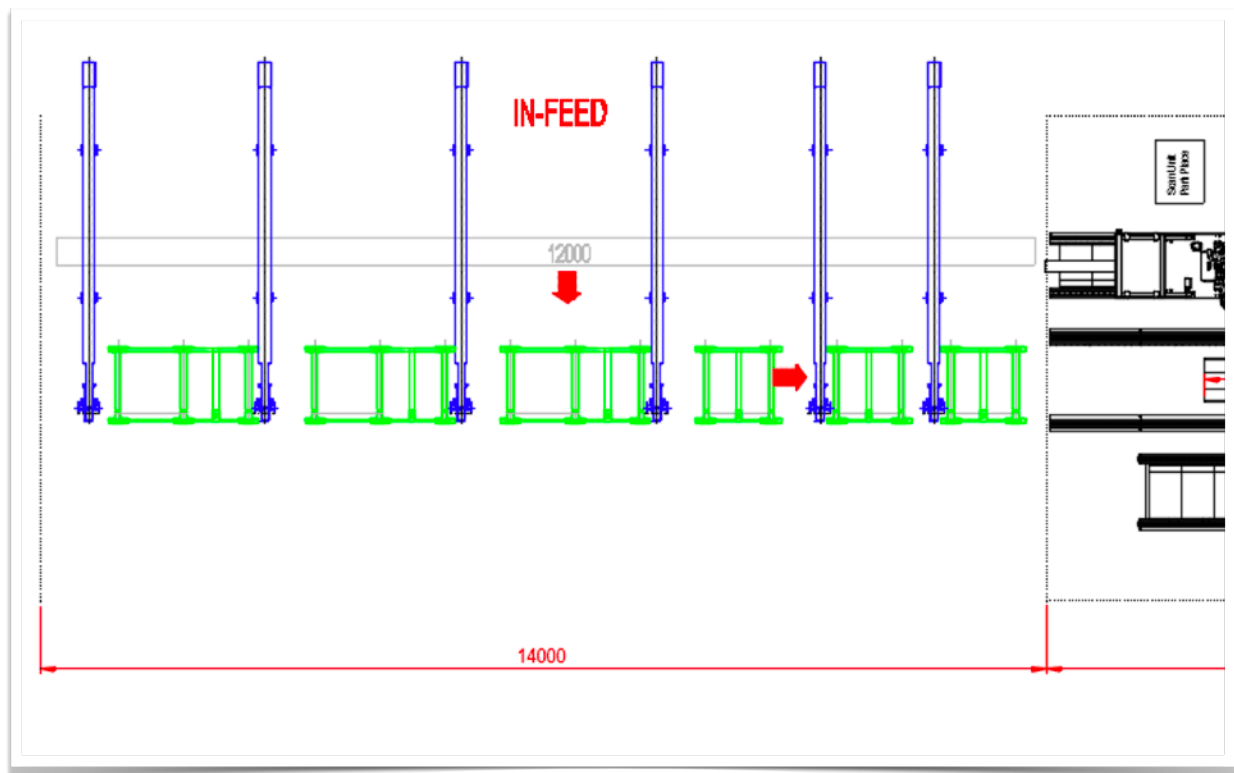

OPTION #12

Out-feed conveyor system:

In order to mechanize the out feed for Agen System. It comes with one slidable cross- conveyor and mechanized lifter.

